

1. Description

Large Battery banks (especially Lithium batteries) place a heavy demand on an alternator, with the potential for significant heat build-up which in turn reduces output and can damage the alternator, as a solution ElectroMaax offers a remote rectifier for our GenMaax alternator 250 12 V and 165 24 V models to address this condition.

Remote rectification has been in use for decades in industrial applications to eliminate the heat build-up in the alternator due to the internal rectification (AC to DC conversion). The advent of advanced battery technologies such as; LiFePO4 , super A.G.M and Carbon Foam have placed higher demands on the alternator; remote rectifiers minimize issues created by these new battery types.

Removing the rectifier from the GenMaax 250 12 V and 165 24 V alternators and placing it remotely, has many benefits including improved air flow through the alternator and elimination of a heat source. The Remote Rectifier comes pre-wired on the GenMaax alternator requiring only primary positive / negative connections, ignition power input and tachometer output. Double rectification ensures sensitive electronics are not compromised.

In systems having a low-voltage warning (D+ connection), an additional relay is supplied to provide this function. Refer to section #4 (below).

2. Specifications

Parameter	Value	Units
Capacity- output	250 @ 12 VDC or 165 @ 24 VDC	Amps
Temperature Range	-40 to 305 (-40 to 150 °C)	°F
Rectification	Double	
Cooling	Cross flow Forced air fan	





Air flow cooling ports

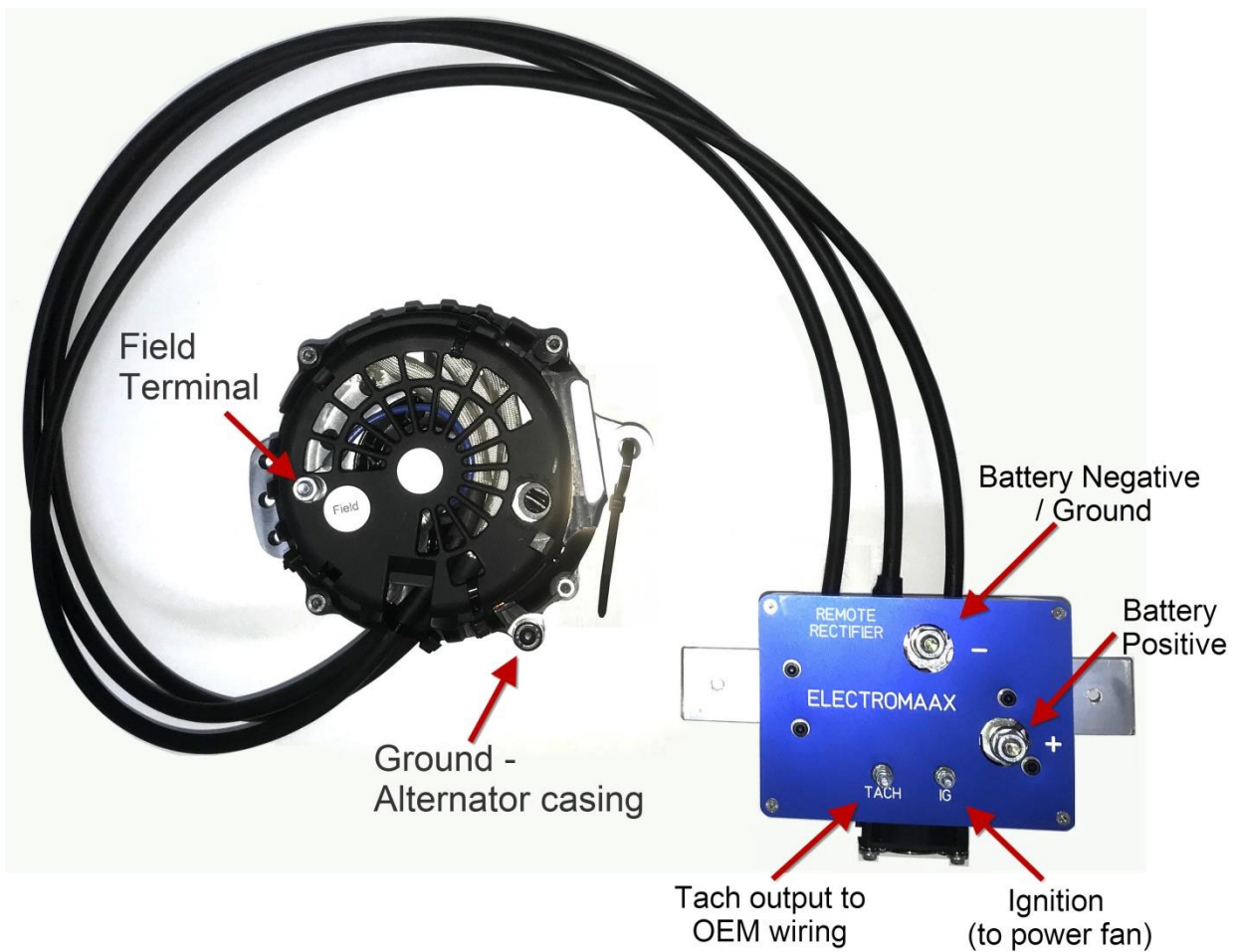

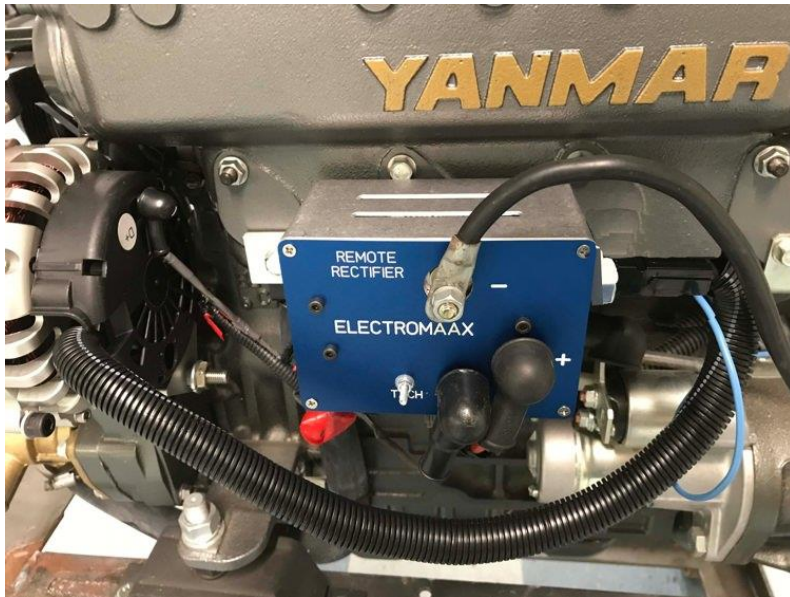

3. Dimensional outline

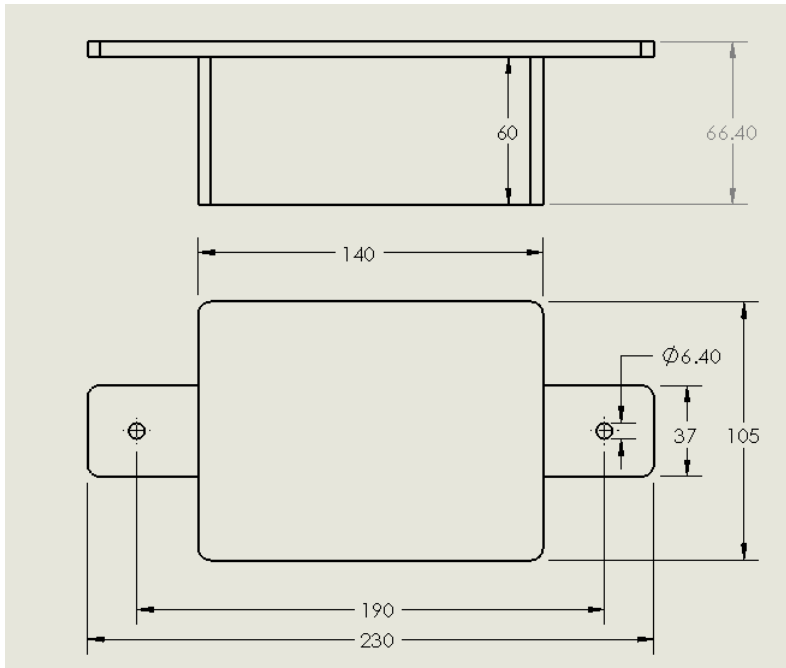

All units are millimeters

Notes:

Notice

ElectroMaax reserves the right to make product modifications or discontinue products without notice. Customers are advised to obtain latest written specifications prior to ordering products. Information provided by ElectroMaax is believed to be accurate at the time of its release. Products sales are subject to the ElectroMaax Terms of Sales in force at the time of order acknowledgment. ElectroMaax products are not designed, authorized, or warranted for use in life support devices and systems, or any other critical applications which may involve death, injury, property or environmental damages. Using ElectroMaax products for any critical application is fully at the risk of the customers and their end users and assigns.

Canada:
5552 King St, Beamsville, ON L0R 1B3
Phone: 905-945-8800
Fax: 905-563-8806

USA:
Unit 5, 6405 Inducon Drive West, Sanborn, NY 14132
1-866-945-8801
Revision - 4