

Introduction

Thank you for choosing an ElectroMaax “GenMAAX” SUPER high-output, marine alternator. This ElectroMaax's line of reliable and robust high output marine alternators, the GenMAAX combines ultimate performance with simplicity. We purposely engineered these GenMAAX alternators to give your batteries the maximum amperage when your vessel needs it the most, when the engine is at idle. This enables you to put substantial amounts of energy (amps) into your batteries while minimizing engine run time, fuel consumption, pollutants and noise. Every GenMAAX alternator meets or exceeds CSA, USCG, ISO, CE and SAE ignition protection standards. They are all extremely straight forward to install onto most marine engines, without modifying your engines mounts. We demonstrate the performance of each GenMAAX alternator, by individually testing them on our State of the Art test equipment, which provides a detailed performance printout.

When used in conjunction with the ElectroMaax “E-MAAX CSR, PRO or PLUS smart exterior regulators”, your new GenMAAX alternator can provide even greater efficiency when charging Life Po 4, Firefly, deep-cycle flooded, standard flooded, gel, AGM, Optima and other marine battery technologies.

All our E-MAAX smart regulators, will guide your alternator through a charging program that’s tailored to provide your batteries with the best care possible.

Safety Considerations

Before installing your new alternator, please take a moment to consider the following guidelines for safe alternator installation and operation. Failure to follow these guidelines could result in injury or damage to your vessel’s electrical system.

1. Always disconnect your batteries and turn your battery switch to its “OFF” position prior to installing your alternator.
2. Remove any loose fitting clothing or jewelry which could become entangled in your motor or other machinery.
3. Wear ANSI-approved safety glasses or eyewear.
4. Ensure that the engine has cooled sufficiently before beginning installation.
5. DO NOT install your high-output alternator without ensuring that the system wiring is sufficiently scaled to handle increased amperage loads.
6. Ensure that your work area is sufficiently ventilated and that no fuels or solvents are present in and around your work area.
7. DO NOT operate your charging system without proper fusing. Failure to do so could result in severe injury and/or damage or loss of your vessel. DON’T take chances with fusing.
8. DO NOT attempt installation while using alcohol or medications which could impair your judgment or reaction time.
9. Use the right tool for the job. Use of improper tools could result in damage or injury.
10. Take time to read the manual. Equipment damage and possible injury may result from an incomplete understanding of the proper installation and use of the alternator.

CAUTION: The following instructions are intended for use by experienced marine electrical installers. If you are not sufficiently experienced with marine electrical systems, we recommend a qualified electrician be used for installation.

Basic Installation

Alternator Mounting

Due to the many domestic and international configurations of engine/alternator mounts, and factors such as year and location of engine manufacture and marinization, ElectroMaax cannot guarantee a drop-in replacement in every engine application. Choose the model that most closely fits your application. Your installer may have to adapt the basic mounts to fit your needs. The majority of marine engines are equipped with one of four alternator mounting styles. The following describes which alternator represents each specific mounting style:

1. SM-Series (Dual Foot with 3.15" between legs): Small Case. Replaces most small case styles using a saddle style mount (e.g., Hitachi, Lucas, Mitsubishi) Most Yanmars.



3.15" Saddle

2. FM-Series (1or 2" Single Foot): Small Case. Replaces most domestic styles using a single 1or 2" mounting foot (e.g., Motorola, Prestolite).



1or 2" Foot

3. J180-Series (Dual Foot with 4" between legs): Small Case. Replaces most Volvo Penta alternators using a 4" Mounting Style



"J180" Mount

4. PM-Series (2" Pad Mount) Series: Small case. Replaces Korean (Mando type) alternators using dual 2" static pad mounting feet. (Found on many Mercruiser and Volvo Penta gas engines.)



Pad Mount

Once you have determined that the new alternator is the correct replacement for your existing model

1. Disconnect the batteries and/or turn the switch to the "OFF" setting. Disconnect the wiring from the existing alternator.

2. Loosen the mounting & tensioning bolts and remove the existing alternator.

3. Once the alternator is disconnected from the engine, compare its mounting points to those on your new GenMAAX alternator. In most applications, the new GenMAAX will replace the old alternator without any modification. In some cases, a simple bracket can be fabricated by a local machine shop. Others can be obtained through your local auto or marine supply.

4. Attach the mounting foot of the new GenMAAX to its engine mount. Some shimming may be necessary to ensure that the alternator is securely mounted within the engine mount. If your alternator is a dual foot style, use care when tightening the alternator in place that the two mounting ears are not compressed. The rear bushing is designed to slide to tighten the mount.

5. Once in place, inspect to ensure that the alternator pulley is properly aligned with the engine pulley. If your belt configuration includes the pulley for the water pump, make sure that all three pulleys are properly aligned. Some shimming or modification to the alternator mount may be required to assure proper alignment.

6. Connect the output cable (see cable sizing recommendations below) ground, field wire, stator (tach) wire if needed and other necessary wiring. Connect alternator to regulator wiring harness as indicated in wiring diagram included the alternator's positive and ground cables should be sized according to the chart on Page 3.

7. If a new regulator is being installed along with the alternator, complete its wiring installation according to the instructions included with your regulator.

Additional Installation Information

Sizing Battery Cables

The addition of a high-output alternator to your charging system may make it necessary to increase the size of your battery cables to increase the system's amperage carrying capacity. To determine the proper cable size, consider BOTH cable length and alternator capacity. Both positive and negative wire runs must be included in your computation.

In other words, when determining battery cable size, we need to consider the "round trip" distance. Wire size may be calculated with the formula $CM=K \times I \times LE$ (whereas CM represents the circular mil area of the conductor, K represents the mil-foot resistance of copper, I represents current, and L represents the length, in feet, of the round-trip cable run and E represents voltage drop in volts). When using this equation, a K constant of 10.75 indicates copper's mil-foot resistance and voltage drop should be calculated at 3% (the standard for critical functions affecting the safety of vessel passengers). In most cases, it may be much simpler to use the following chart as your guideline:

Battery Cable Sizing

Length (feet)	5	10	15	20	25	30	40	50	75
AMPS									
75	8	6	4	2	2	1	1/0	2/0	4/0
100	8	4	2	2	1	3/0	4/0		
125	6	4	2	1	1/0	3/0	4/0		
150	6	2	1	1/0	2/0	3/0	4/0		
175	6	2	1	1/0	2/0	3/0	4/0		
200	4	2	1/0	2/0	3/0	4/0			
225	4	1	1/0	2/0	3/0	4/0			
250	4	1	2/0	3/0	4/0				
275	4	1	2/0	3/0	4/0				
300	2	1/0	3/0	4/0					
350	2	1/0	3/0	4/0					

Grounding

All ElectroMaax alternators are case grounded, i.e., the alternator establishes its connection to the system ground via the engine block. While the ground is "built into" its engine mount, we recommend that a secondary ground cable be added to the alternator case. The installed ground cable should be equal in size to the positive output cable as indicated on this page. We do construct some GenMAAX alternators with isolated ground, be sure to read the manual that is applicable when using one.

Fusing

The American Boat and Yacht Council (ABYC), in its standards for safer boating, recommend that cable runs to your battery banks be fused to protect the boat and owner against damage and injury. Circuit protection, as described by ABYC standards, can be accomplished by installing either a resettable circuit breaker or a fuse. The fuse or breaker you choose will depend on both the amperage rating of the alternator and the size of cable used. Blue Sea Systems, a respected manufacturer of high-quality fuses and circuit breaker devices, recommends the following when sizing the proper circuit protection for your system. Fusing should be:

1. The largest available circuit protection device smaller than the amperage capacity of the cable being protected.
2. Larger than the maximum continuous current that will flow in the circuit. We find that a circuit protection device sized at approximately 140% of your alternator's rated amperage is typically suitable for the circuit being protected. For more info about circuit fusing, see <http://www.blueseasystems.com/circuit.htm>.

After the alternator is installed and the wiring connections are attached, inspect the pulley for proper tension. When changing pulleys or when using the factory-installed pulley, torque the shaft nut to 50-60 foot-pounds. The shaft nut measures 15/16".

To install the belt:

1. Loosen the adjustment arm bolt and alternator pivot assembly bolt.
2. Fit a new, high-quality belt over the appropriate pulleys.
3. Tension the alternator until the belt is securely tightened in place. Retighten the pivot assembly and tension arm bolts. To test tension, place a 15/16" wrench on the alternator shaft nut and apply pressure. If the pulley rotates without moving the belt, re-loosen the bolts, apply additional pressure, and re-tighten. Repeat until the belt is properly tensioned.
4. Verify proper tension by pushing on the outside surface of the belt. The belt should deflect approximately 1/4" to 5/16" under moderate pressure. Your local auto parts store may carry a measuring tool designed to gauge belt deflection.
5. Ensure that the Mounting bolts at the alternator's pivot point are securely re-tightened.

For ease of belt installation, you may want to invest in an inexpensive belt tensioning tool. This simple

tensioner provides positive support at the alternator while increasing belt tension, leaving two free hands to re-tension mounting and tensioning belts. Your belt will tend to stretch during the first several times you run your engine. Make it a part of your normal preflight check to test belt deflection and re-adjust belt tension when needed. If you notice an accumulation of black belt on your alternator and surrounding engine area, check belt tension.

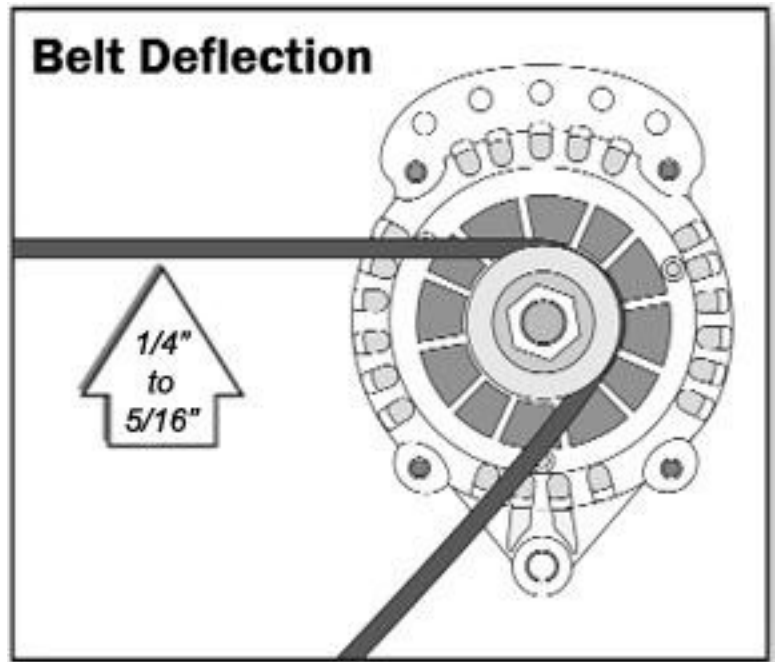

Pulleys

All GenMAAX alternators rated at 215 amps plus come standard with only serpentine or dual 1/2" v belt pulleys.

Alternator Heat

During operation, your GenMAAX will become hot as a result of friction and the generation of inductive current. In some instances, particularly during extended periods of heavy load, alternator case temperature can exceed 200 degrees (F). Corrections of conditions causing overheating are strongly advised. Use extreme caution when handling the alternator or other engine components during or after use. Should your alternator become so hot that it emits a burning smell, or if there is indication of discoloration at the pulley or pulley shaft, shut off the alternator immediately and (once it becomes safe to inspect the alternator) check the tension of the drive belt. Under and over-tensioned belts are the leading cause of overheating and alternator damage. See the Troubleshooting section, later in the manual, for alternator inspection guidelines. For those vessels with Life Po4 batteries or very large battery bank The GenMAAX RR (remote rectifier) 250 amp, is recommended exclusively for these applications.

Meters

Replacing your standard alternator with an ElectroMaax high output or Super high output alternator, may dictate that your standard amp meter is replaced with a high amperage, shunt-type meter. We strongly recommend replacing your current amp meter with an upgraded one. If purchasing our E-MAAX PRO this device is also a high amperage output meter, preventing you purchasing additional equipment in addition the E-Maax PRO via its USI (user interface) will indicate battery state of charge as well as estimated battery time remaining before more charging is needed.

Tachometers

All ElectroMaax alternators provide a source of un-rectified AC voltage directly from the stator output. This stator output provides the pulse required to drive most electric tachometers. All ElectroMaax alternators feature 12-pole stator outputs (meaning 12 pulses of AC voltage during each alternator revolution). Many standard and aftermarket electrical tachometers feature some level of adjustment to calibrate the tachometer to your alternator's pole settings and pulley ratios. If your existing tachometer does not provide any adjustability, it may be necessary to replace the existing tachometer with an adjustable model.

Alternator-to-Battery Ratios

In order to achieve optimal performance from your charging system, it is essential to determine the capacity your charging system is capable of supporting. In general, the size rating of the alternator should mirror the acceptance rate of the batteries being charged. Differing battery technologies will vary in terms of their acceptance rates. For example, a deep-cycle flooded battery is typically capable of accepting roughly 25 percent of its available capacity at any given time. As a result, we want our alternator's rated output to equal the acceptance rate of the battery being charged when it reaches its full discharge rate. In other words, a deeply discharged 400 amp hour deep cycle flooded battery would require an alternator rated at 25 percent of 400 amps, or 100 amps to support that bank. In simpler terms, a deep-cycle flooded battery bank will require 25 amps of alternator output for every 100 amp hours of battery rating. Some newer battery technologies, such as AGMs and spiral wound batteries can accept up to 40 percent of their available capacities, as such, alternator output should be increased to reflect the optimal ratio between alternator and battery capacity. Our Life po 4 Batteries will accept 200% of their capacity, that is why you need substantially less energy storage in this technology over flooded or A. G. M.

Failure to meet recommended alternator-to-battery ratios will commonly result in slower charge times, increased alternator heat and wear, and reduced alternator and battery life.

Multiple Bank Charging Options

When charging a single starting battery, the alternator can be connected to the battery directly, or via an ON/OFF switch. More typically, in a marine system, the alternator will be supporting a smaller starting battery and larger house battery bank -- or a starting battery, along with multiple banks for house loads, inverter loads, windlass or thruster. Many methods of multi-bank charge control are available. The following section outlines many of the most commonly used options for multiple-bank battery management:

Switch

Available in two primary types -- ON/OFF or A/B/BOTH -- manual switches offer a simple method for charging management. Possible installations include separate cables to each battery bank with ON/OFF switches in line for each bank, or, a common output cable to the common post of the A/B/BOTH switch with an output cable to each battery bank. Field disconnect switches feature terminals where the field output from the regulator to the alternator can be interrupted when the battery switch is turned to the OFF position. This feature ensures that alternator output is discontinued as soon as the battery is disconnected. NEVER operate the alternator with switches in OFF position (doing so could cause alternator diode damage).

Advantages: Inexpensive. No substantial voltage drop.

Disadvantages: Require user interaction and heightened system understanding. Can be accidentally shut down, causing potential alternator damage. Does not allow for mixed battery technologies. Voltage Sensing: Battery voltage sensed must always be that of battery being charged. Sense voltage at common side of battery switch or at alternator positive output.

Combiner

Battery combiners enlist high-amperage solenoids to charge multiple battery banks. Below a specific voltage set point, the combiner's solenoids remain open, isolating the individual battery banks. Once the baseline voltage is reached, the solenoid(s) open, combining all of the batteries into one big bank.

Advantages: No user interface required. No substantial voltage drop. Available in 2 or 3-bank models.

Disadvantages: Moderately expensive. Does not allow for mixed battery technologies. Voltage Sensing: Sense voltage at common side of combiner or at alternator positive output.

Isolator

Isolating diodes direct charging current to the battery bank with the greatest demand, best suited for battery banks that are comparable in size and degree of discharge. Isolators are not necessarily the best choice when charging house and start battery banks. Only one battery bank can be sensed by the regulator, so under or overcharging- can be a substantial issue if batteries are dissimilar in capacity or degree of charge. Diodes can drop voltage at the battery side of the isolator by nearly a full volt, which means that the alternator is forced to increase voltage far in excess of that needed by the batteries.

Advantages: No user interface required, reasonably priced, Available in 2 or 3-bank models.

Disadvantages: Substantial voltage drop, Can only sense voltage at one battery bank, May drive voltage at secondary battery bank to dangerously high levels. May hold high voltage for too long at smaller bank. Tendency to under or overcharge secondary (non-sensed) battery bank, Greater chance of early battery failure. **Voltage Sensing:** Voltage must be sensed at most commonly used battery bank (typically house). Connect sense wire to battery side of isolator or positive post of battery being sensed.

Notes

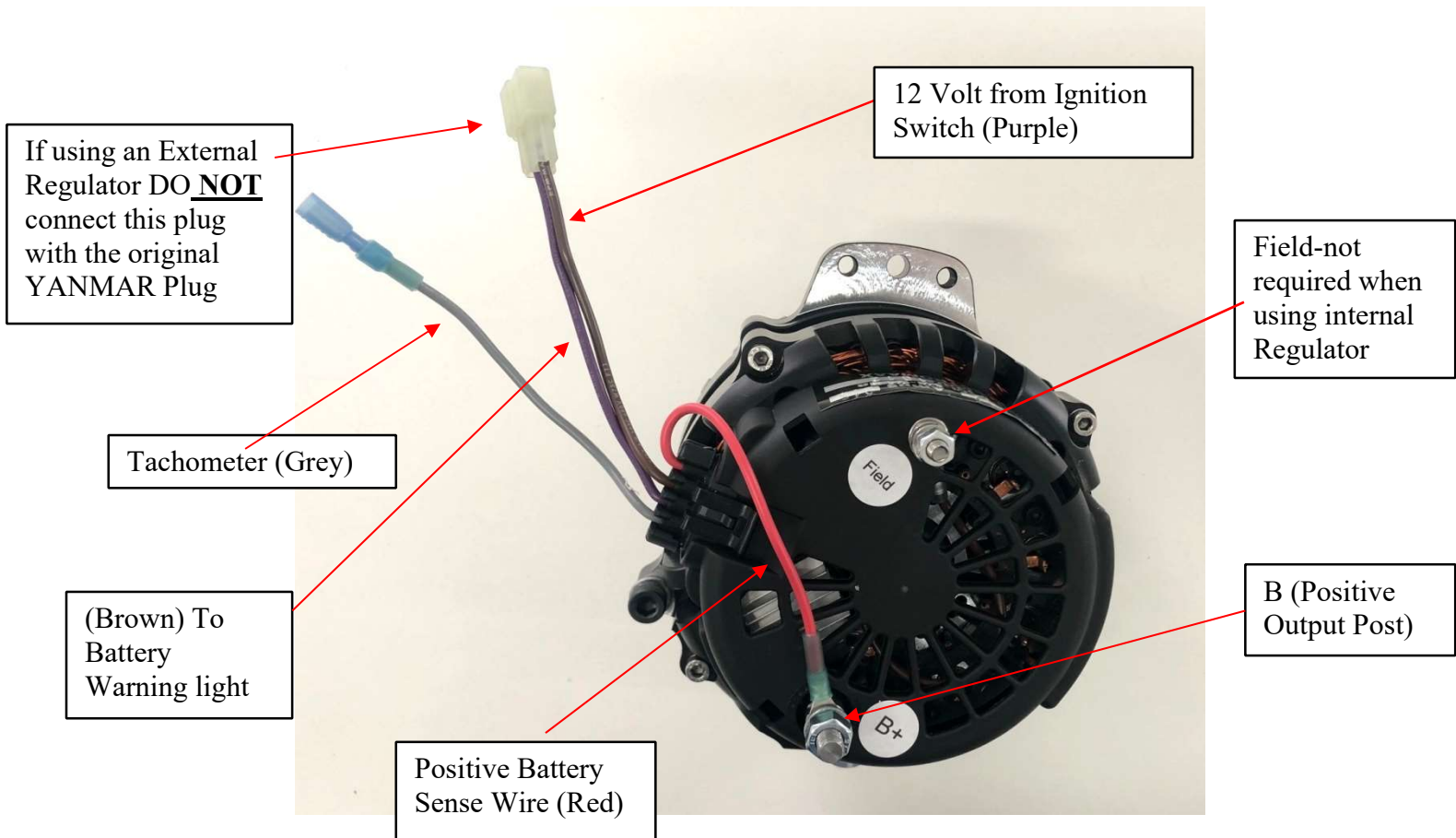

ElectroMaax’s “GenMaax” alternators feature a simple, two-stage regulator that can be used as a standalone unit or as an emergency back-up unit in conjunction with an external regulator.

Customers with a Yanmar Engine can simply connect their original alternator plug to our units plug making it now a simple plug and play

When used with an external regulator the field wire is connected to the 6mm post – This is a positive excitation alternator.

IF USING AN EXTERNAL REGULATOR, WE RECOMMEND FOLLOWING THE INSTRUCTION THAT COME WITH THAT REGULATOR

Genmaax Wiring Connections when using ElectroMaax E-Maax CSR Regulator

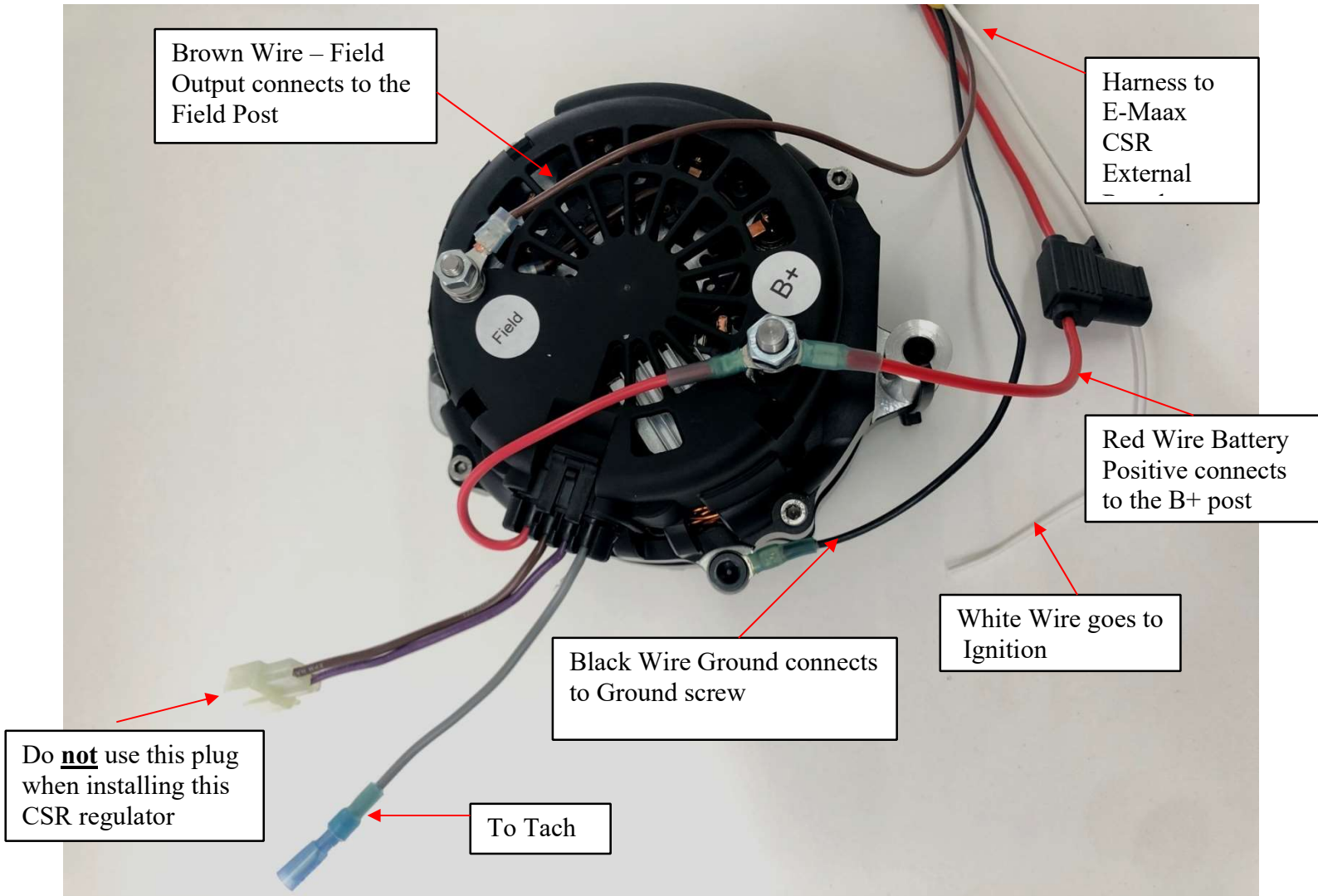

Please refer to the E-Maax CSR Regulator User Manual for more in depth details

Genmaax Wiring Connections when using ElectroMaax E-Maax PRO Regulator

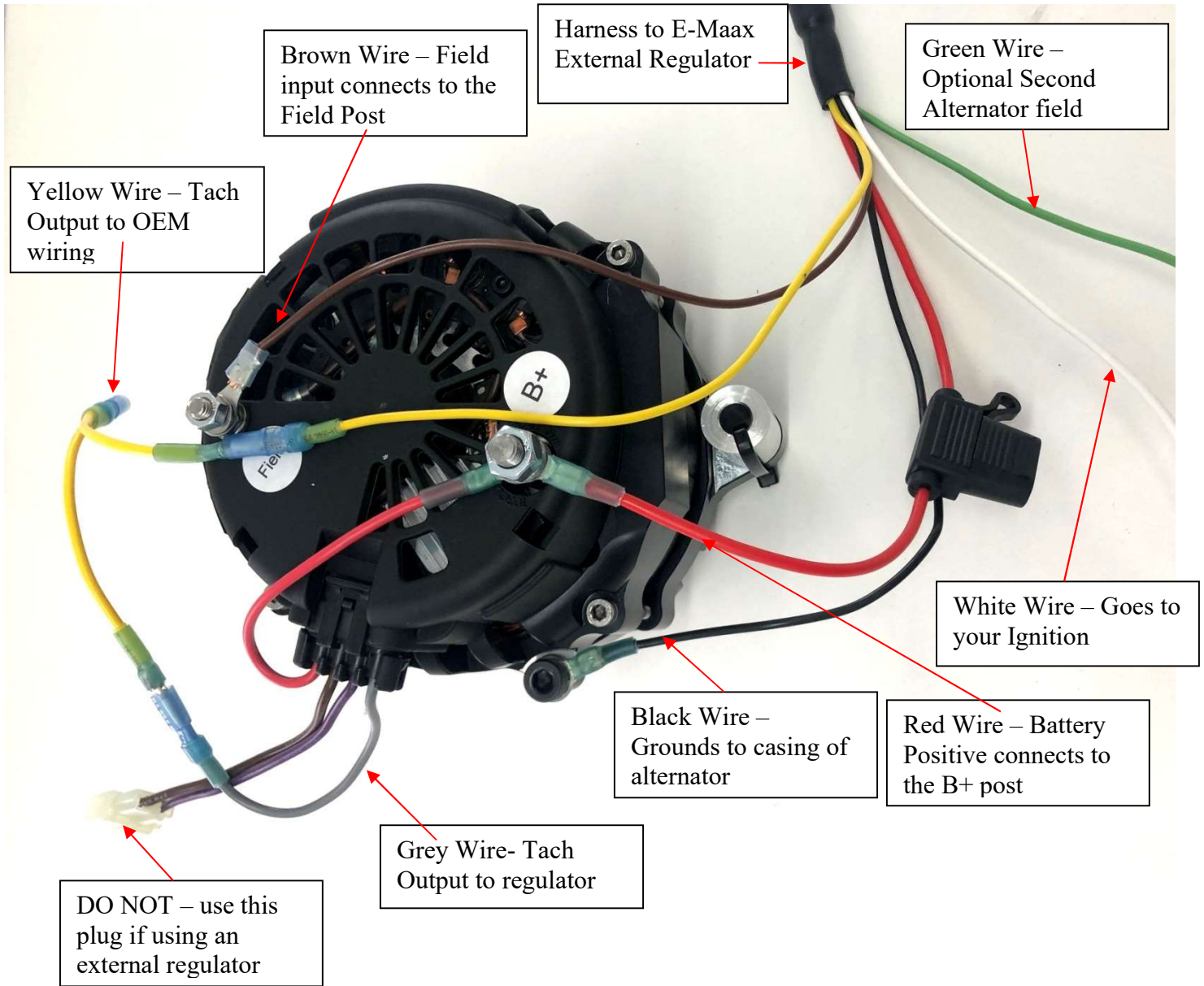

Please refer to the E-Maax PRO Regulator User Manual for more in-depth details

24 Volt GenMaax Wiring Connections when using an External Regulator

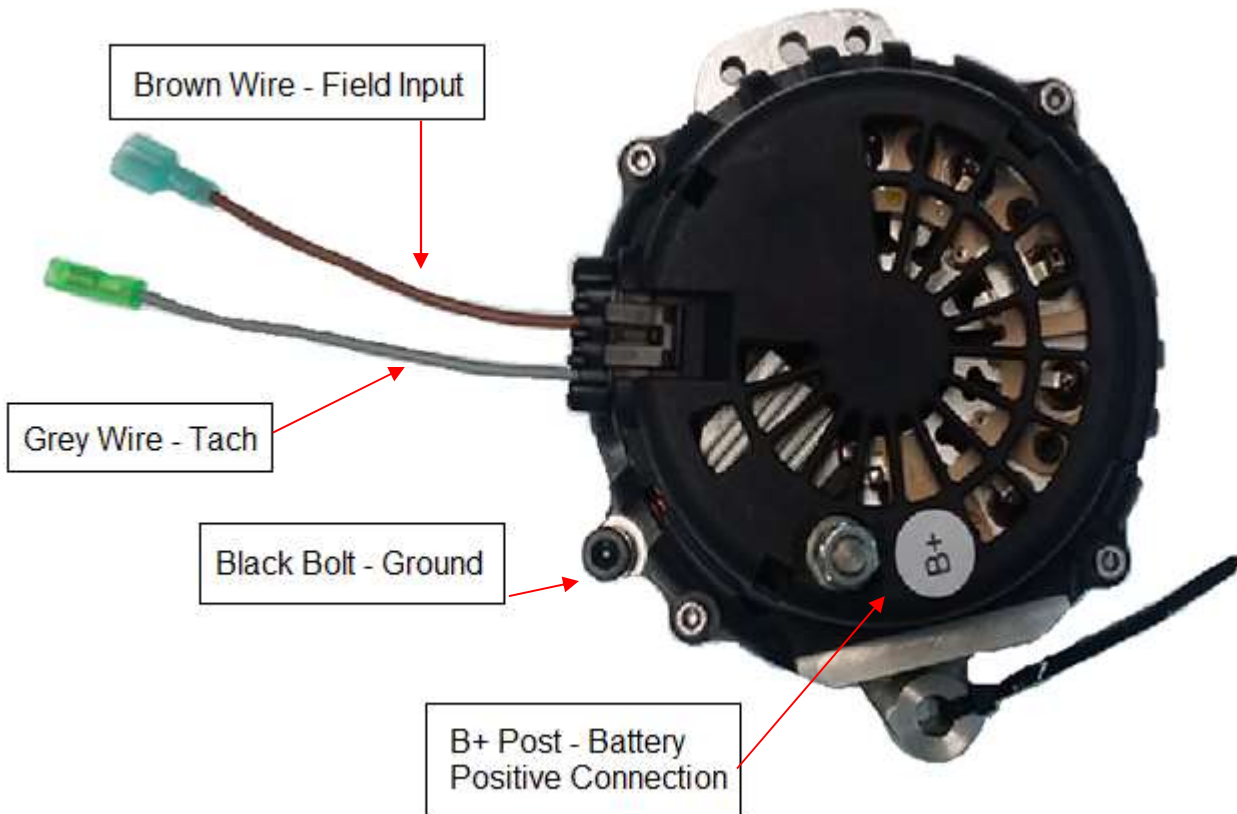

If using an external regulator, we recommend following the instructions that come with that regulator



Warranty Information

LIMITED PRODUCT WARRANTY

ELECTROMAAX warrants to the original consumer/purchaser the product is free from any defects in material or workmanship for a period of one year from the date of purchase. If any such defect is discovered within the warranty period, ELECTROMAAX will replace the defective part free of charge, subject to verification of the defect or malfunction upon delivery or shipping prepaid to ELECTROMAAX. This warranty DOES NOT apply to defects or physical damage resulting from abuse, neglect, accident, improper repair, alteration, modification, or unreasonable use of the products resulting in breakdown, cracked or broken housings nor are parts damaged by fire, water, freezing, collision, theft, explosion, rust, corrosion or items damaged in shipment en route to ELECTROMAAX for repair. ELECTROMAAX assumes no responsibility for consequential damage or loss or expense arising from these products or any labor required for service or repair.

ELECTROMAAX WILL NOT repair or be held responsible for any product sent without proper identification, return address and Return Authorization (RA) number clearly marked on the package. You must include proof of date and place of purchase (photocopy of purchase invoice) or we cannot be responsible for repairs or replacement. In order to expedite warranty claims more efficiently, ELECTROMAAX asks that prior to returning a defective product for repair, you call ELECTROMAAX’s Customer Service department for a warranty return authorization number.

If factory service is required, you can contact our ELECTROMAAX Customer Service Department Monday through Friday, 8:30 AM to 5:00 PM, (EST) 1-866-945-8801.

Material required for the repair or replacement for the defective part or product is to be supplied free of charge upon delivery of the defective product to ELECTROMAAX, 5552 King Street, Beamsville, Ontario, Canada, L0R-1B3. Customer is responsible for all return transportation charges and any air or rush delivery expense. ELECTROMAAX reserves the right to determine whether to repair or replace defective components. Returned warranty or non-warranty items deemed non-repairable will be disposed of after 30 days, unless claimed by owner. ELECTROMAAX is not liable for damage to or loss of returned items.

THE ABOVE LIMITATIONS MAY NOT APPLY TO YOU. SOME PROVINCES AND STATES DO NOT ALLOW LIMITATIONS ON HOW LONG AN IMPLIED WARRANTY LASTS. NO PERSON, AGENT, DEALER IS AUTHORIZED TO GIVE ANY WARRANTY.

US Customer Address
ElectroMaax USA
6405 Inducon Drive
West
Unit 5
Sanborn. NY.14132

Canadian Customer
Address
ElectroMaax
5552 King Street
Beamsville, ON, L0R 1B3

Phone: 1-866-945-8801

Fax: 1-905-563-8806

Email: support@ElectroMaax.com

Website: www.ElectroMaax.com

*** Customers MUST return units to proper address. Any duty fees on return units will be responsibility of the customer.*