

Contents:

1. Background: 1
2. System Components: 1
3. Installation: 3
4. Fault Diagnostics: 5
5. Visual Indications: 7
6. Reference schematic diagrams: 8
7. Reference connection diagrams: 9
8. Summary: 10

1. Background:

The E-MAAX PRO regulator addresses the historical problems associated with optimizing alternator charging capacity under typical marine applications. A marine charging system must perform under a highly variable charge / load state while often operating under a limited time duration (sail boat). The ability to respond to large load variations, coordinate multiple charge inputs such as, solar or wind, as well as provide the specific charging profiles required for the various battery technologies is critical to a system’s performance.

The E-MAAX PRO ensures the alternator, whether a generic alternator or one of ElectroMaax’s high output alternators, provides the optimum charge profile to satisfy the various battery technologies and the current operating conditions. The E-MAAX PRO continually monitors both system voltage and current flows, combined with the input from 3 temperature sensors provides both a safe-guard and a control function, ensuring system integrity and performance is optimized.

The control algorithms and a high-speed communication network ensure fast, accurate response to any of the charge / load conditions experienced in a marine application. The rapid response capability ensures any transient electrical events, even under the most extreme situations, are handled effectively with a fail-safe action.

The supplied *USI interface* brings all available performance parameters to a single PC screen. A full complement of peripherals and sensors, delivers the performance parameters that allow owners to evaluate “at a glance” their vessels charging system. The same interface allows factory-based diagnostics through *E-MAAX ReMote* technical support.

2. System Components:

The PRO system is comprised of the following components:

- PRO module
- Power Cable
- Temperature Sensors (x2)
- Current Sensors (x2)
- Sensor Hubs (x2)
- Com Module or Com Module PLUS
- Voltage Sensor

PRO Regulator Module:

PRO Regulator Module is housed in a durable plastic enclosure 15x10 cm, with 5 connection ports; the first connection port is a 6 pin power connection. Any of the other four 4-pin connection ports will accept the various accessory devices. The face surface of the enclosure has 2 multi-color LEDs, used for status indication. PRO Regulator Module controls alternator output via Field output, and utilizes micro-processor

based communications to monitor battery and alternator temperatures. The PRO is factory programmed specific to the end-users system, that is:

- System voltage (12 or 24)
- Battery Technology (Lead acid / AGM / GEL / Spiral Wound / TPPL / FireFly / Custom / LiFePO₄)
- Alternator configuration (P or N)

Power Cable:

The 2-meter Power Cable is a 6-wire connection cable which plugs into the PRO module via the 6-pin quick-connector.

Wire color codes:

- Black = Battery Ground
- Red = Battery Positive
- White = Ignition (keyed)
- Brown = Field Output
- Yellow = Tachometer Signal

Refer to the wiring schematics below for additional connection information.

Temperature Sensors:

The battery and alternator temperature sensors are colored coded (Black=Battery / Silver=Alternator). Provided with the standard 3 meter (10 ft.) connection cable; extension cables can be purchased if required for additional length. The sensor end has the electronics encapsulated into the aluminum housing ready for mounting via the 8 mm (5/16") hole. The face side of the sensor has a status indicating LED. The connection end is the 4-pin moisture tight connector for the module. Refer to the "[Temperature Sensor Datasheet](#)" for additional information regarding functionality.

Current Sensors:

Current sensing provides an improved level of charge regulation over basic voltage sensing, providing both faster response and system load sensing. Current Sensors are installed to monitor current rates at both the battery and the alternator. Electrical usage (load) is monitored via the battery current sensor. Refer to the "[Current Sensor Datasheet](#)" for additional information regarding functionality.

Sensor Hubs:

Sensor hubs allow multiple sensors to connect to the PRO module. It is recommended that one Sensor Hub be designated for the Battery (Temp / Current / Voltage) and another Hub for similar Alternator sensors. Refer to the "[Sensor Hub Datasheet](#)" for additional information regarding functionality.

Com Module and Com Module PLUS:

Provides both a USB based user interface and a *Field Reduction Switch* for limiting alternator output. The Com Module is typically mounted in the "Nav Station" allowing computer connection via the 1m (3ft) supplied USB cable. Com Module PLUS in addition provides a Bluetooth connection to a computer, audible alarm, and ability to reduce the alternator output in 10% increments. Connection to the PRO is via any of the 4-pin ports.

The operating parameters can be remotely displayed into a PC via the Com Module. The following data will be displayed:

- System Voltage
- Regulator Temperature
- Battery Temperature
- Alternator Temperature
- Field Output %
- Charging Stage
- Ignition Status
- Field Reduction Switch Status
- Critical Fault Status
- Setting Fault Status
- Battery Current
- Alternator Current

- Battery Voltage
- Engine RPM
- Battery State of Charge (SOC)

Refer to the "[Com Module Datasheet](#)" or "[Com Module PLUS Datasheet](#)" for additional information regarding functionality.

3. Installation:

The PRO Regulator has been designed with marine environment and the boater in mind. The PRO is a compact, module system requiring minimal tools and spatial requirements, the system can be easily installed by a DIY boater. The module is secured using 2 screws; allow room for access to the connection ports along the lower edge. Refer to "[PRO Regulator Datasheet](#)" for wiring connection information. Various available peripherals allow for system enhancement with simple "Plug and Play" convenience. All connectors for the PRO regulator allow only a single orientation position connection, please note when inserting.

Sequence of actions:

1. Mount the regulator in a suitable location close to the engine and battery using two M6 or ¼" screws. Plug the Power cable into the PRO regulator.
2. Mount the *Alternator Temperature Sensor* on a suitable location on the alternator case, so the sensor's LED indicator is visible. Good temperature transfer should be provided between the alternator case and the sensor. Connect sensor's cable to any available port of the Sensor Hub.
3. Mount the *Battery Temperature Sensor* onto the battery either to a stud or directly to the battery housing so the sensor's indicator is visible. Good temperature transfer must be provided between the battery and the sensor. Connect sensor's cable to any available port of the Sensor Hub.
4. Mount the *Com Module* or *Com Module PLUS* in a suitable location such as the "Nav Station" to allow connection to a PC via the 1m USB cable. Connect the 4-pin plug to any available port of the PRO regulator (extension cable available if required).
5. Mount Battery Current sensor in "series" with the main battery positive "load" cable, typically going to positive bus bar. It is important to observe the measured current direction. The direction indicator must point towards the battery as this is considered "negative flow"..
6. Mount the Alternator Current Sensor in "series" with the alternator output cable. It is important to observe the measured current direction. The direction indicator must point towards the battery; this is considered as "positive flow".
7. Connect the measuring leads of the Battery Voltage Sensor To the battery posts. It is recommended to observe the polarity when connecting the sensor's leads to the posts.
8. The Power Cable consists of 6 wires, (Black / Red / White / Brown / Green / Yellow) requiring the following connections ;
 - a. Black – The primary ground connection on the alternator or bus-bar.
 - b. Red – The primary positive connection on the alternator (B+ post)
 - c. White – The switched side of the ignition switch. Ensure voltage is present only when the ignition switch is "ON" (first position).
 - d. Brown – Field input of the alternator.
 - e. Green – not used
 - f. Yellow –tachometer signal

The Power cable is connected to the PRO regulator via the 6-pin connector in the 6-pin port (see schematics below). Once the PRO system is installed and connected, the boat electrics can be enabled. Visual status and diagnostics are provided via the LED indicators. Refer to "[PRO Regulator Datasheet](#)" for details regarding the LED functions.

Cruiser Wiring Connections

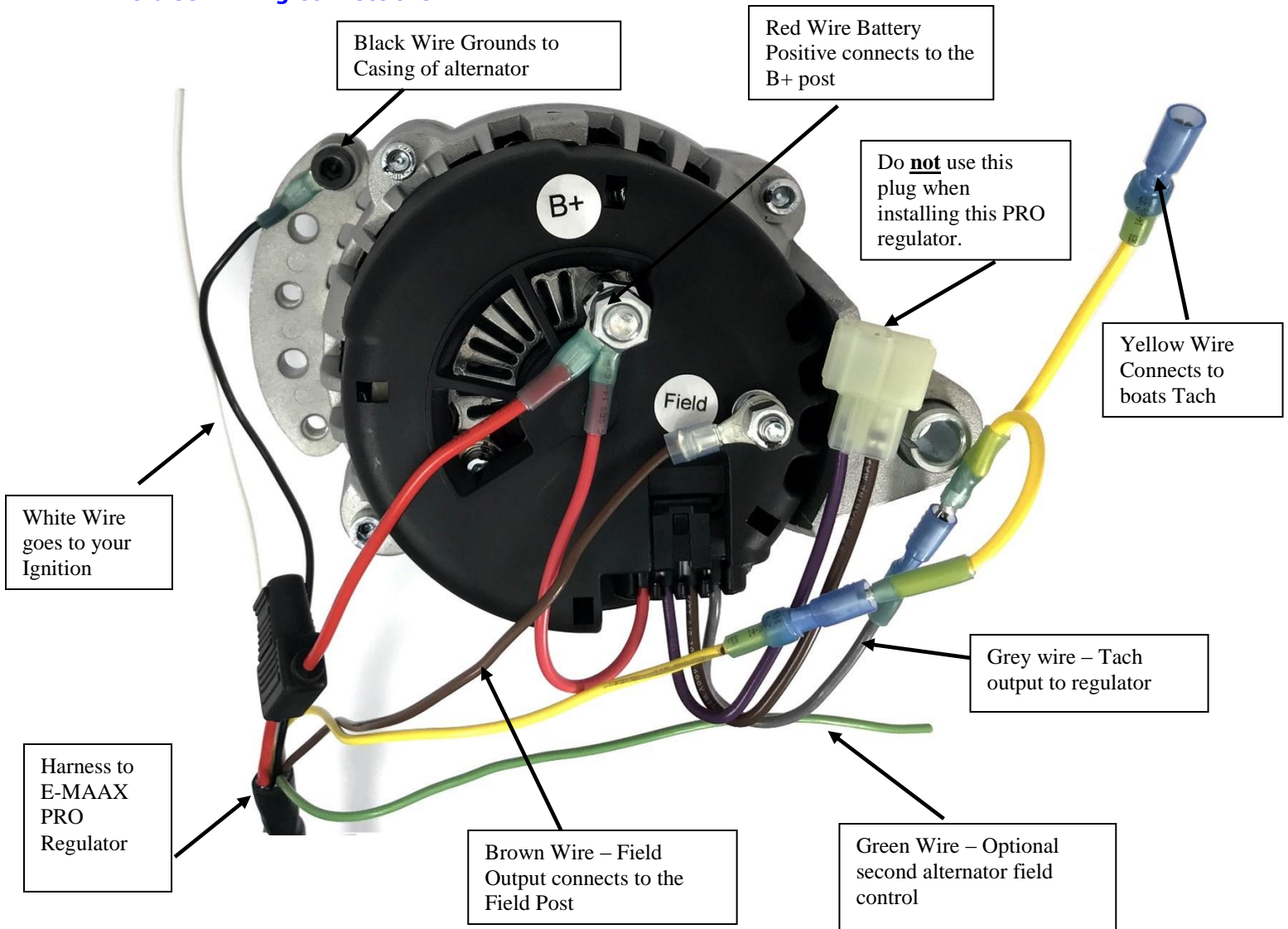

Warning Alarm Relay – For connections providing low-voltage warning light and/or audible alarm (D+ connection) please refer to the Universal Lamp Relay Kit Installation Instructions which can be found on our website under Support – Manuals & Specifications.

<https://electromaax.com/site-uploads/1001178/Files/Warning-light-relay-wiring.pdf>

GenMaax Wiring Connections

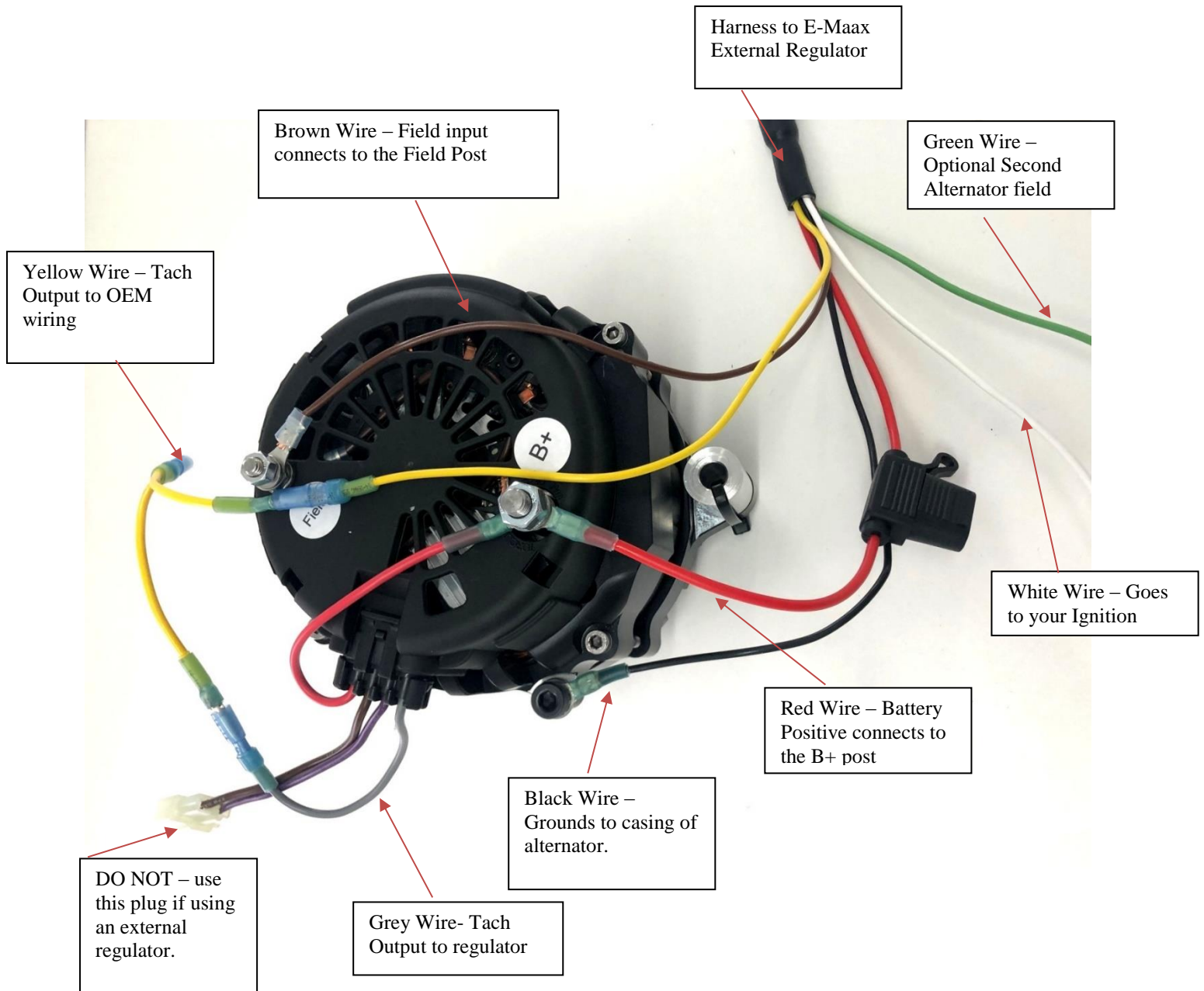

Warning Alarm Relay – For connections providing low-voltage warning light and/or audible alarm (D+ connection) please refer to the Universal Lamp Relay Kit Installation Instructions which can be found on our website under Support – Manuals & Specifications.

<https://electromaax.com/site-uploads/1001178/Files/Warning-light-relay-wiring.pdf>

4. Fault Diagnostics:

The PRO module is programmed to detect and display various system alarm states, with a corresponding mitigating action. The specific alarm is defined by the LED indicators.

Refer to the "*PRO Regulator Datasheet*" for information regarding reading the alarm state, the corresponding PRO action and required remedy. The following information regarding alarm states is taken from the "*PRO Regulator Datasheet*";

Warning condition:

Warning condition is a special mode of regulation when the Field Output is reduced to 50% of its nominal value for the current charging conditions. The regulator is placed into the Half Field condition due to one or more of the following conditions:

- a) The battery's temperature reaches 40° C
- b) The alternator's temperature reaches 90° C
- c) The regulator's temperature reaches 60° C
- d) Engine RPM is below "*Anti-Stall*" value. The *Anti-stall* feature is designed to ensure that the alternator load does not compromise engine performance. The threshold value is factory set; when the warning condition is enabled the engine rpm gauge in the USI will display a yellow background.

Warning condition is indicated by the right LED flashing red once per second. Half Field condition is re-set automatically when the following situations occur;

- ignition is switched off
- alarm condition is cleared

Critical Fault condition:

Critical Fault condition is an alarm mode (right LED flashing red two times quickly) when Field output is restricted to 10% in order to avoid damage to the charging system. The regulator is placed into the Critical Fault condition due to one or more of the following conditions:

- a) The battery's temperature has reached 50°C
- b) The alternator's temperature has reached 100°C
- c) The regulator's temperature reached 90° C
- d) In-line fuse on the power supply line is blown
- e) Overvoltage

Critical Fault condition does not require restart of the regulator; it is re-set automatically when the fault condition is cleared.

Settings Fault condition:

Settings Fault condition is an alarm mode (periodically flashes red three times) when no Field output is supplied to the alternator in order to avoid damage to the charging system. The regulator is placed into the Settings Fault condition due to one or more of the following conditions:





- a) The regulator has not been configured by ElectroMaax
- b) The regulator is configured for a 12-Volt system and a 24-Volt system has been detected
- c) The regulator is configured for a 24-Volt system and a 12-Volt system has been detected
- d) Alternator's parameters have not been set

To clear the Settings Field condition requires the trigger condition to be eliminated and the restart of the regulator.







5. Visual Indications:

PRO Regulator has two LED indicators.

Left indicator works only when the ignition is inactive and there is no regulation.

Lighting sequence	Meaning
	Regulator is powered up, ignition is switched off. It flashes (ISO) green every 6 seconds.
	Regulator is busy reporting its settings to external PC
	Regulator is busy importing its settings from external PC and the settings have not been accepted
	Regulator is busy importing its settings from external PC and the settings have been updated

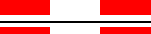
Right indicator works only when the ignition is active and there is regulation.

Lighting sequence	Meaning
	Warm-up stage of regulation
	Bulk+Absorb stage of regulation
	Float stage of regulation
	Half Field condition, when regulator allows 50% of the alternator's output
	<i>Critical Fault condition</i> , when regulator allows only 10% of the alternator's output
	<i>Settings Fault condition</i> , where the regulator disables the alternator's output (0%).
	CSR mode of regulation (basic regulation based on system voltage)

6. Reference schematic diagrams:

P-type alternator

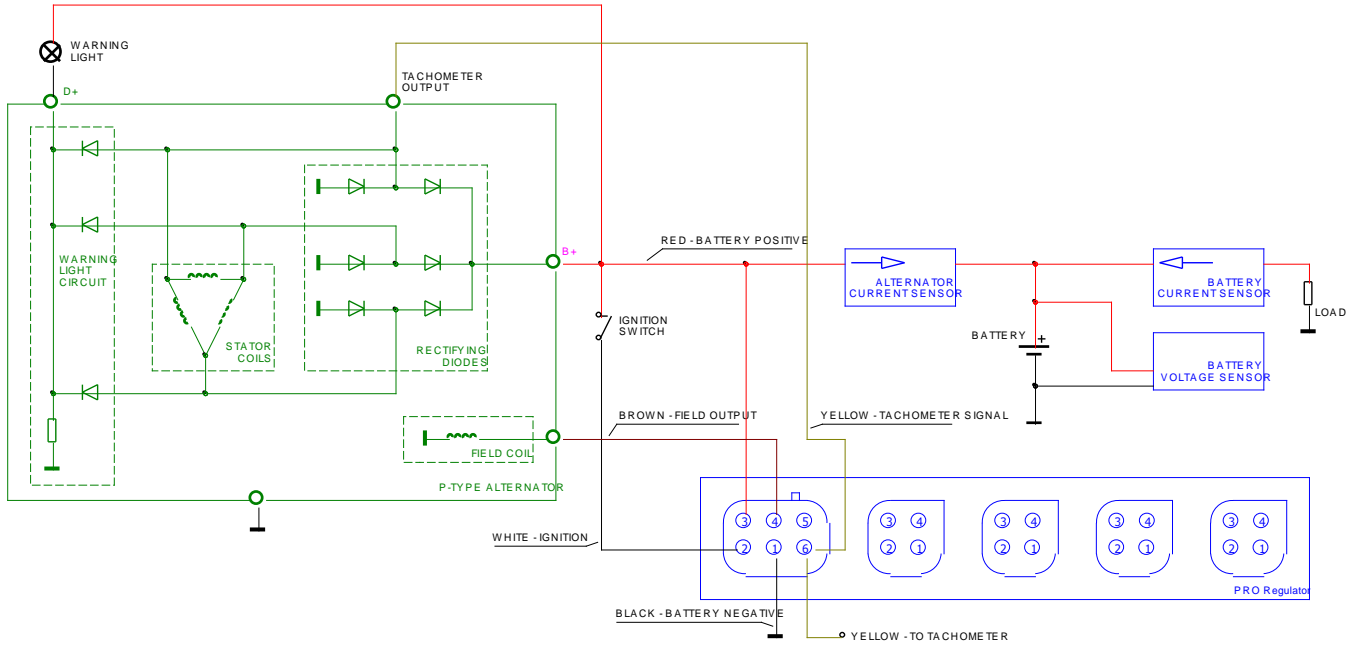

N-type alternator

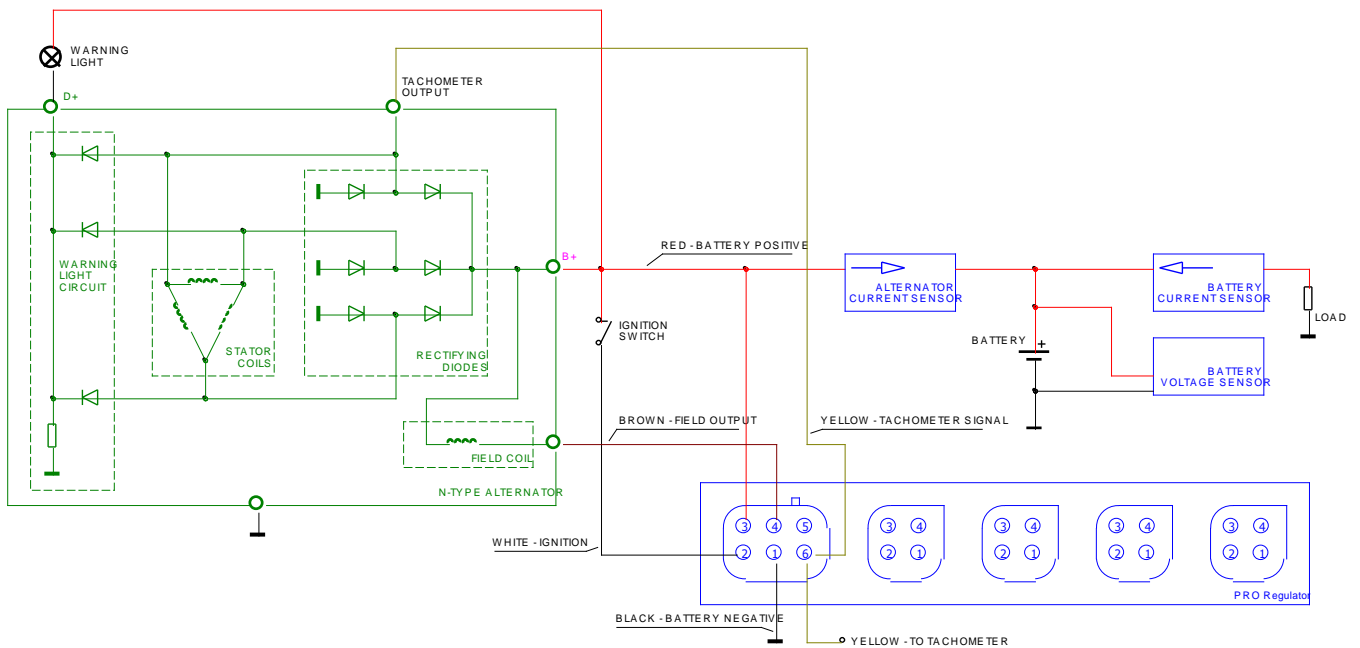

7. Reference connection diagrams:

Reference diagram for connections to a standard battery, including the ElectroMaax P3-12/114AH Lithium Ion.

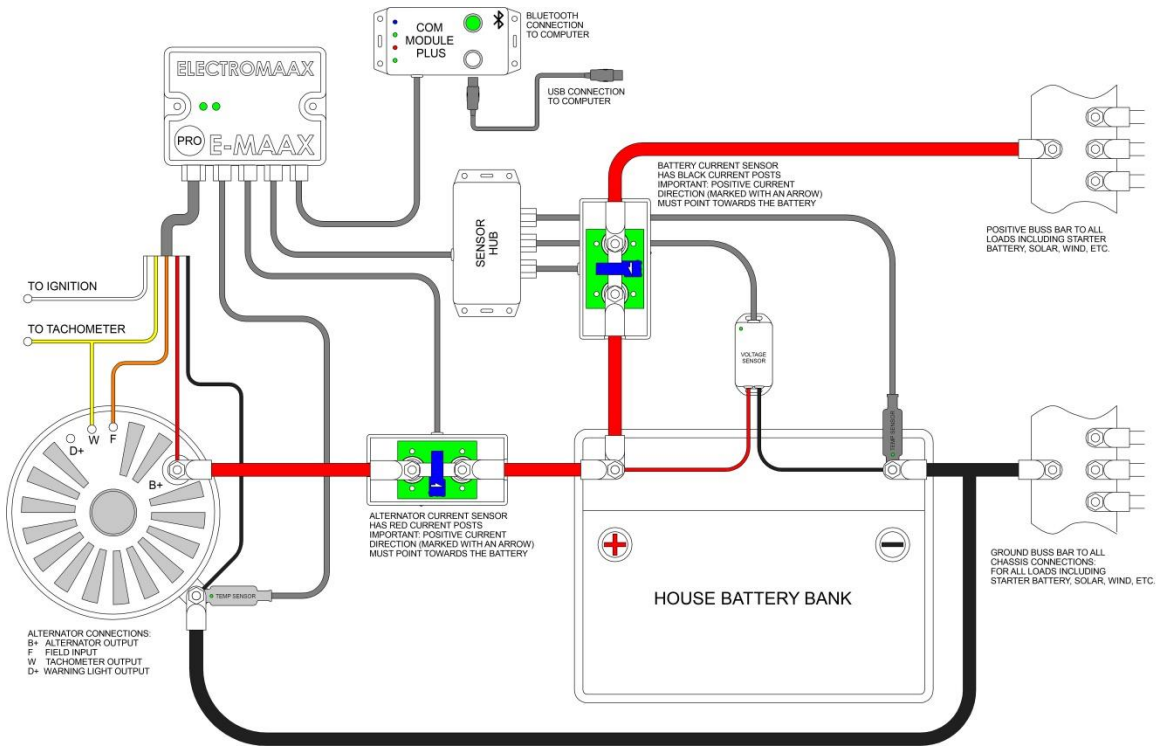

Connection diagram for standard battery; system equipped with Remote Rectifier.

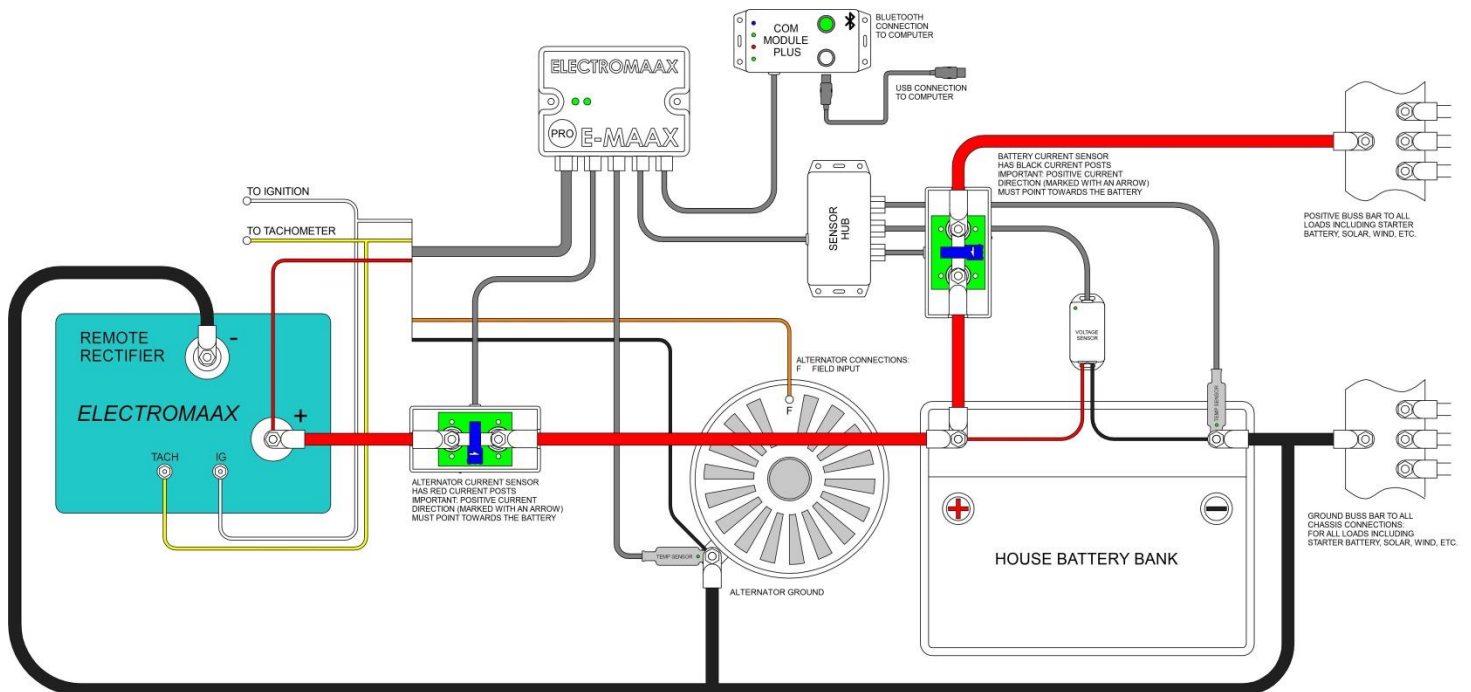

8. Summary:

A properly installed PRO Regulator system does not require any user adjustments.

The PRO Regulation system provides a robust, reliable technology developed to optimize marine electrical charging requirements, while providing both system safe-guards and diagnostics.

Designed to reduce system connection complexity, allowing DIY boaters the ability to fault diagnose and remedy most common problems, thereby providing confidence and security in this critical area of marine service. The E-MAAX PRO is designed to provide years of reliable performance.

Notes: